



直角銑頭 MILLING HEAD

油壓鎖鬆刀直角銑頭
Hydraulic Tool Clamping /
Unclamping 90° Milling Head

XR11

- 本體結構強化
- 高轉速時低振動值
- 低溫升/低噪音
- Main Body Structural Strengthening
- Low Vibration Value At High Speed
- Low Temperature Rise / Low Noise

專業製造 **50** year
Manufacture

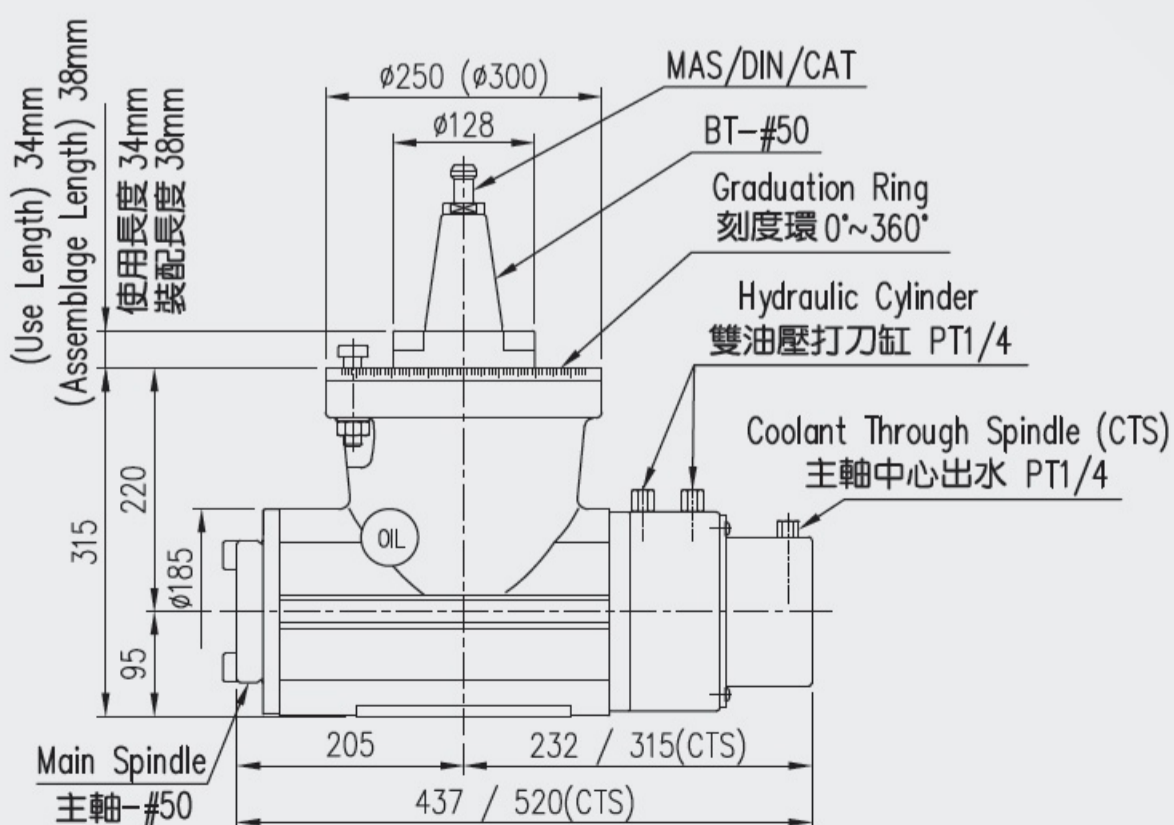

加大四方型本體，可承受更大扭力，亦適用於立車及大型龍門。配有打刀缸，可快速換刀，且其採用之四瓣爪，拉刀力強、使用年限久。

做鑽深孔用時可選配中心出水。

Adopting enlarged square main body can bear greater torque. It is also suitable for vertical lathe, large gantry milling machine. With unclamping cylinder, which can change the tool quickly, and the OTT pull stud type clamping units, make the tool clamping force strong and long service life.

Optional accessories coolant through spindle for deep holes drilling.

- 主軸孔端斜度/Spindle Taper: ISO 50
- 最高轉速/Max. Speed: 2000 rpm / 3000 rpm
- 法蘭介面外徑/Outside Diameter of Flange: $\phi 250/\phi 300$