

XHA75/XHA75C 重切削直角銑頭 / 90° HEAVY DUTY MILLING HEAD

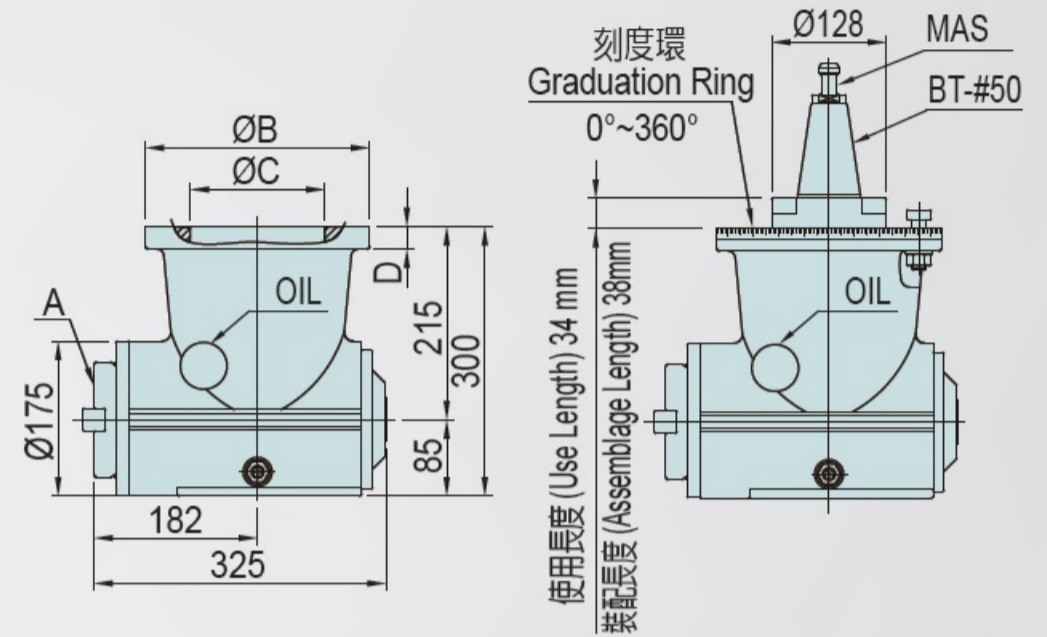

- 主軸孔端斜度 : ISO 50
- 法蘭介面外徑 : Ø250 / Ø300
- 最高轉速 : 1500 rpm
- Spindle taper : ISO 50
- Outside diameter of flange : Ø250 / Ø300
- Max. speed : 1500 rpm



單位/Unit: mm

Model No.	A	B	C	D	最高轉速 Max. Speed	最大扭力 Max. Torque	切削材料 Cutting Material	進刀深度 Depth of Cut	進刀速度 Feed Speed	進刀轉速 Spindle Speed
XHA75	ISO-50	Ø250	Ø150	25	1500 rpm	1000 N-m	S45C	3	350	250 rpm
							FC25	7	400	220 rpm
XHA75C	ISO-50	Ø300	Ø180	30	1500 rpm	1200 N-m	S45C	4	350	250 rpm
							FC25	7	400	220 rpm

XD90A / XD90 / XD90AC / XD90C 雙向直角銑頭 / Bi-directional 90° MILLING HEAD



- 主軸孔端斜度 : ISO 50
- 法蘭介面外徑 : Ø250 / Ø300
- 最高轉速 : 800 rpm / 2000 rpm
- Spindle taper : ISO 50
- Outside diameter of flange : Ø250 / Ø300
- Max. speed : 800 rpm / 2000 rpm

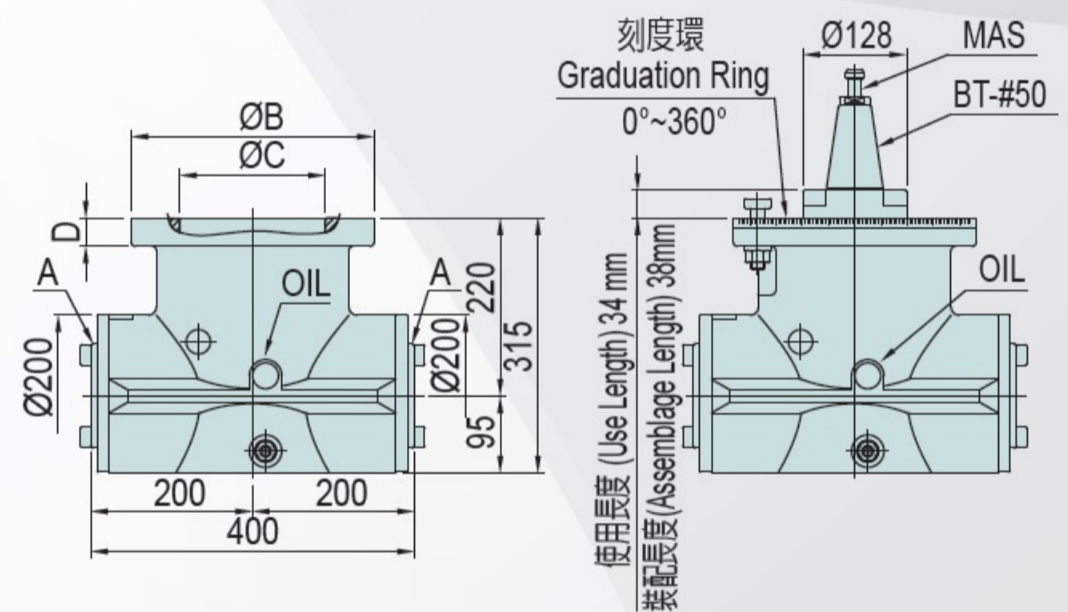

單位/Unit: mm

Model No.	A	B	C	D	最高轉速 Max. Speed	最大扭力 Max. Torque	切削材料 Cutting Material	進刀深度 Depth of Cut	進刀速度 Feed Speed	進刀轉速 Spindle Speed
XD90A	ISO-50	Ø250	Ø150	30	800 rpm	1000 N-m	S45C	4	350	250 rpm
							FC25	7	400	220 rpm
XD90AC	ISO-50	Ø300	Ø180	35	800 rpm	1200 N-m	S45C	4	350	250 rpm
							FC25	7	400	220 rpm
XD90	ISO-50	Ø250	Ø150	30	2000 rpm	1000 N-m	S45C	3	350	250 rpm
							FC25	5	400	220 rpm
XD90C	ISO-50	Ø300	Ø180	35	2000 rpm	1200 N-m	S45C	3	350	250 rpm
							FC25	5	400	220 rpm

OH YOUNG MACHINERY CO., LTD.

📍 台中市太平區41154號工業十六路33號
No. 33, Gongye 16th Rd., Taiping Dist.,
Taichung City 41154, Taiwan

☎ 886-4-2271-5699 / 886-4-2271-5379
☎ 886-4-2271-5299
✉ ohyoung@ohyoung.com.tw

